

Pompe centrifuge CP08

Pompe centrifuge universelle dédiée au relevage de condensats de splits cassettes.

Réf : CP08SC6641

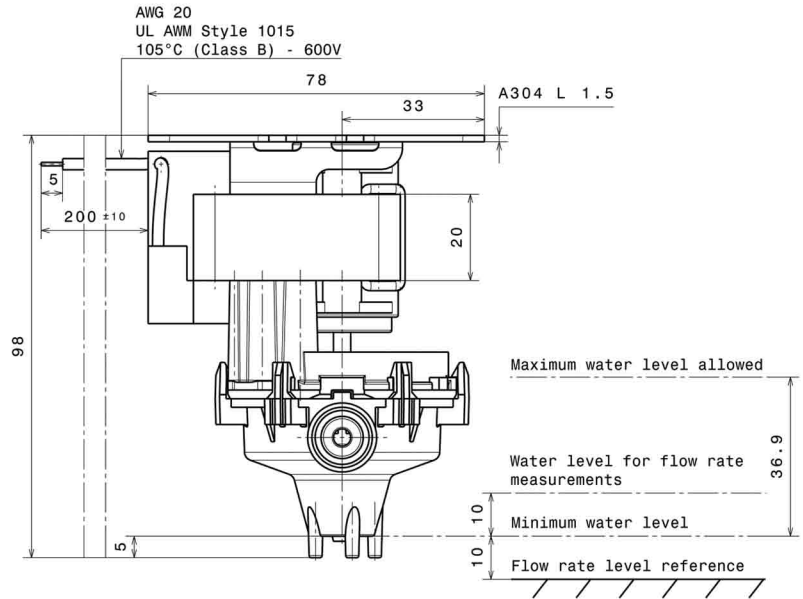
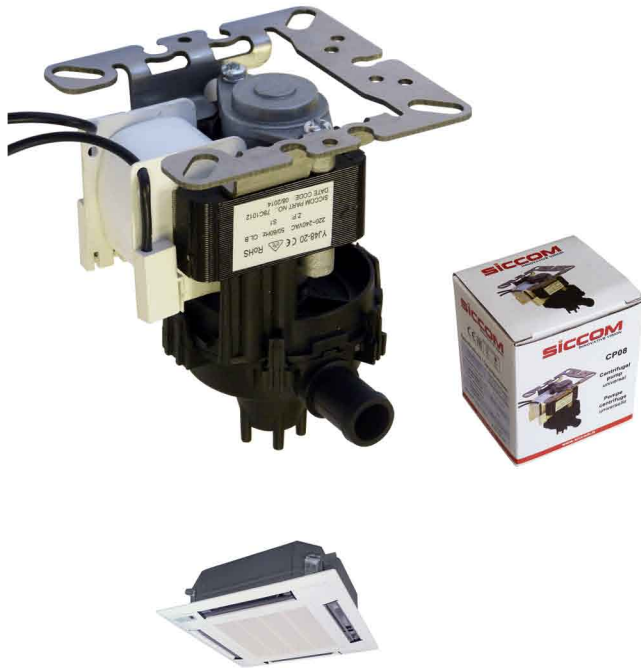

Caractéristiques techniques

Débit max	60 l/h
Hauteur de refoulement max	110 cm
Puissance électrique	8W
Tension électrique	220-240V 50/60Hz
Niveau sonore	26 dBA @ 30cm
Protection IP	IP54
Élévation de température max en rotor bloqué	66 K
Facteur de marche*	100%
Tube d'évacuation	Ø 14 mm
Dimensions	82.5 x 76 x 97.3 mm

* La pompe est capable de fonctionner 100% du temps si nécessaire.

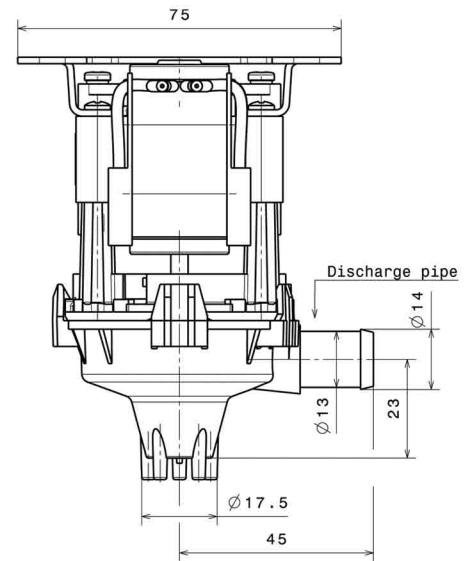

Courbe de débit

